

BEVERAGE CUP HOLDER - MAINTENANCE PRACTICES

1. General

- A. This section includes the removal and installation procedures of the cup holders.
- B. There are two styles of cup holders that can be installed in the airplane. The original cup holder is a ring-style cup holder that can be found attached to the instrument panel. The new style of molded cup holder can hold a wider range of cups, and can be found attached to the control column cover.

2. Ring Style Cup Holder Removal/Installation

- A. Remove the Cup Holder (Refer to Figure 201).
 - (1) Remove the screw, washers, spacer and nut that attach the cup holder to the instrument panel.
 - (2) Remove the cup holder from the airplane.
- B. Install the Cup Holder (Refer to Figure 201).
 - (1) Put the cup holder in position to the instrument panel, then attach with the screw, washers, spacer and nut.

3. Molded Cup Holder Removal/Installation

- A. Remove the Molded Cup Holder (Refer to Figure 201).
 - (1) Remove the screws and washers that attach the molded cup holder to the control column cover.
 - (2) Remove the molded cup holder from the airplane.
- B. Install the Molded Cup Holder (Refer to Figure 201).
 - (1) Put the cup holder in position to the control column cover, then attach with the screws and washers.

Figure 201 : Sheet 1 : Beverage Cup Holder

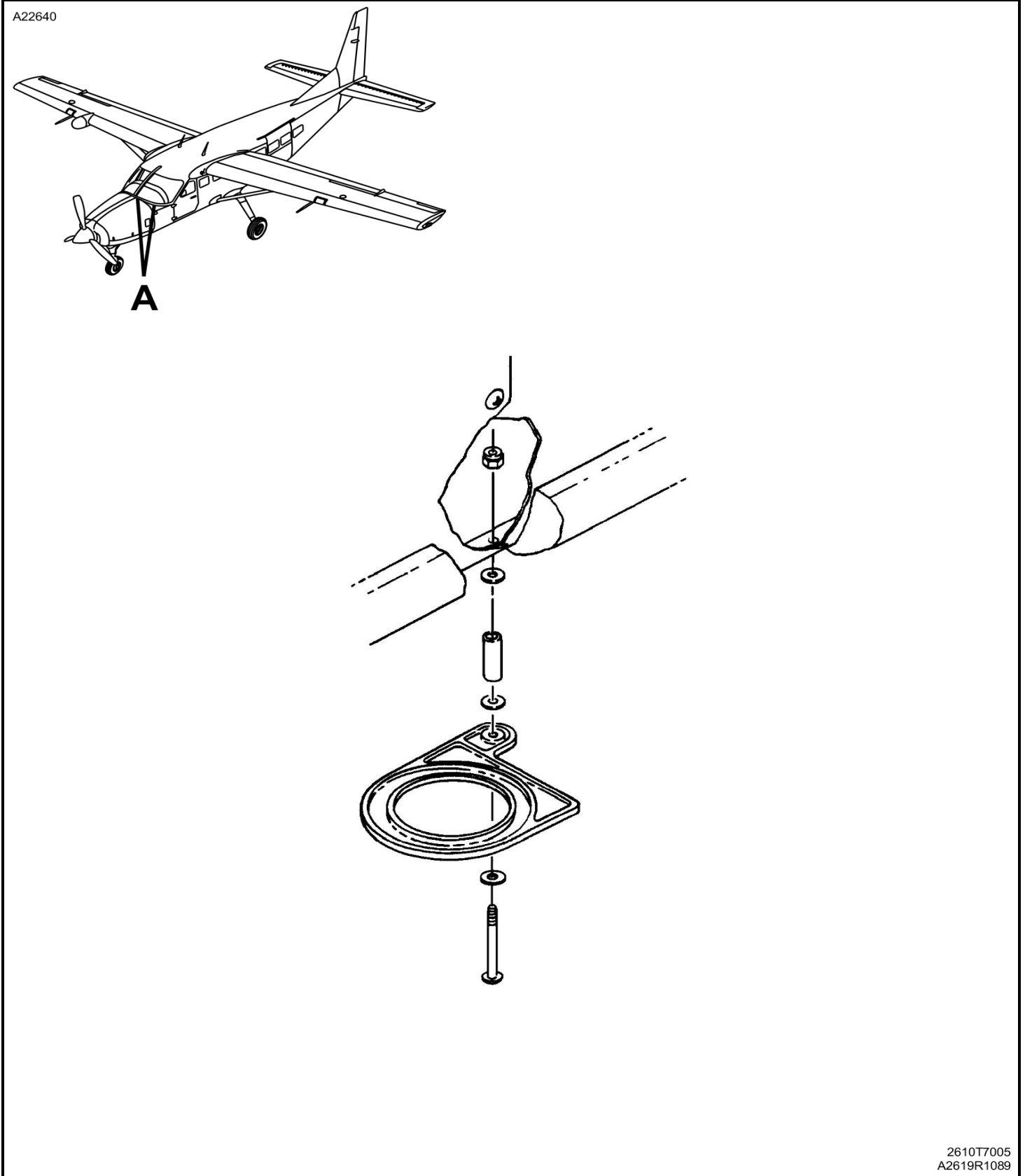

Figure 202 : Sheet 1 : Molded Cup Holder

